

ZIGBEE: A Wireless Technology

Dr. Vaibhav Jain
Physics Department, DAV (PG) College, Bulandshahr, UP, India.

The IEEE 802.15.4 standard offers a new wireless technology aimed at lower power consumption, low cost, low latency and short range communication. "Zigbee" is termed as the commercial name for this standard. This paper presents a review of IEEE802.15.4 standard with a discussion of the MAC layer. Different network topologies have been presented and a comparison of Zigbee with Bluetooth has been given in detail.

Keywords: Zigbee, LR-WPAN, network topologies.

1. INTRODUCTION

Zigbee technology is a low rate, low power consumption wireless networking protocol that is targeted towards automation and remote control applications [1]. The IEEE 802.15.4 committee started working on low data rate standard a short while later. Then Zigbee Alliance and IEEE decided to join hands and Zigbee is the commercial name for this wireless technology.

2. ZIGBEE AND IEEE 802.15.4

Zigbee shares the well established 2.4 GHz band with Bluetooth (IEEE 802.15.1 standard) and Wi-Fi also co-existing in the same band. This is an International ISM (Industrial, Scientific and Medical) band, which is particularly suited for device implementation. Zigbee operates in two other unlicensed bands: 915 MHz in North America and 868 MHz in Europe [3]. The former band has 10 channels with a maximum data rate of up to 40 kbps supported while the later has only 1 channel that supports rate up to 20 kbps. [4]. IEEE standard 802.15.4 will be utilised by Zigbee products to serve applications in wireless sensor networks (WSN) [5], monitoring, remote controls and sensors etc. where relatively low data levels of data throughput are needed.

The standard is casted upon low rate (250kbps in 2.4 GHz band) wireless personal area network (LR-WPAN) based system. Some of the characteristics of LR-WPAN are –

- 1) Data rates of 250, 100, 40, 20 kbps.
- 2) Low power consumption
- 3) Low latency
- 4) Energy detection

Two major types of devices outlined in the IEEE 802.15.4 protocol are full function device (FFD) and reduced function device (RFD). FFD can operate in three modes – (a) PAN Co-ordinator (PC) (b) co-ordinator (c) device. A typical FFD device has the advantage to communicate with another FFD device or with a RFD device while RFD device can communicate only with a FFD device [7]. Thus FFD usually serves as a PAN co-ordinator (PC) and RFD fulfils the task of a nominal device such as a sensor only.

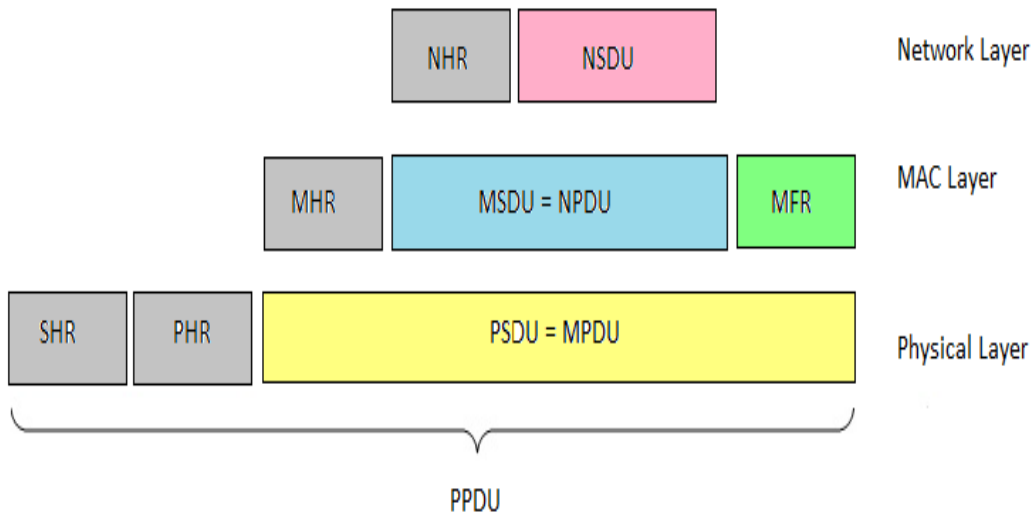

Fig. 1: Structure of the IEEE 802.15.4.

The PHY packet consists of three components: the Synchronization header (SHR), the PHY header (PHR), and the PHY payload. The SHR enables the receiver to synchronize and lock into the bit stream. The PHR contains frame length information and the PHY payload is provided by the upper layers that includes data or commands for the recipient device.

3. NETWORK TOPOLOGY

The basic network topologies supported by the network layer are (a) star, (b) mesh, (c) cluster or tree. In star topology devices have to first send a message to the PAN co-ordinator (PC) in order to communicate with each other. Devices can directly communicate with each other without the intervention of PAN co-ordinator in mesh network topology. Cluster topology shares the features of both star and mesh topology [10].

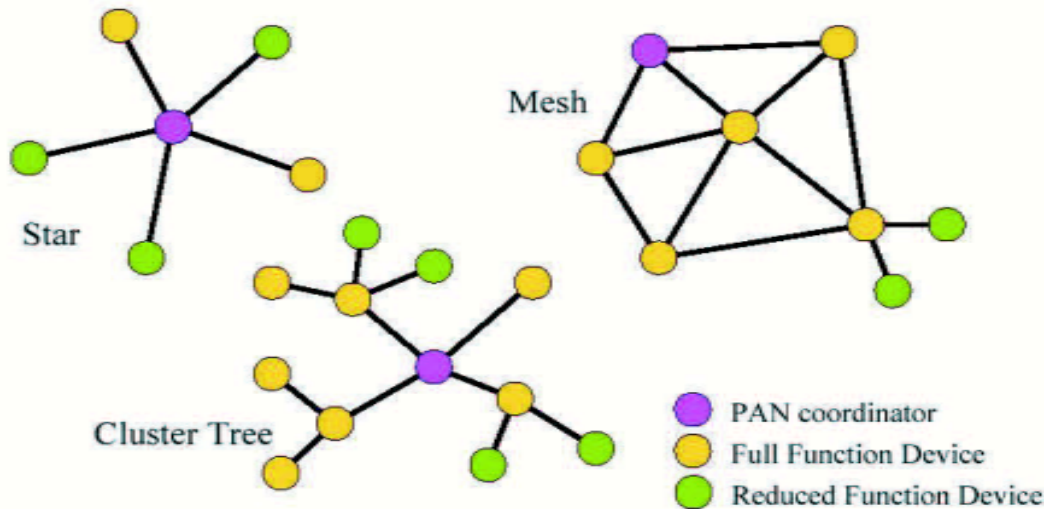

Fig.2: Topology Models.

4. ZIGBEE Vs. BLUETOOTH

Zigbee looks like Bluetooth but is simpler and has a lower data rate capacity. The best way to differentiate between the two technologies is to review the ideas that were laid down during their implementation. Following data provides a more quantitative differentiation between the two technologies:

Code Size: The Bluetooth with a stack of 250Kbytes has an upper hand as compared to Zigbee with only has a stack of 28Kbytes on an average. This is related to lower power consumption and low cost.

Battery Life: Zigbee nodes uses the two AA batteries running for months while Bluetooth devices have a much lower battery life that makes it unfeasible in some situations.

Range: Although Zigbee transmits data at a much lower rate as compared to Bluetooth but the range of transmission exceeds over 100 metres whereas it is only 10 metres in case of Bluetooth.

Networking Capabilities: The Zigbee network supports up to 65536 to millions of devices compared to only 8 for Bluetooth networks.

5. IEEE 802.15.4 MAC LAYER

The two basic services by the mac sub layer are: the mac data service and the mac management service. The transmission and reception of MAC protocol data units are handled by MAC data service. The various features of mac sub layer include beacon transmission, synchronization, association and dissociation.

3.1 Data Transmission Model

The data is transmitted in Zigbee in 2 modes: beacon enabled and non-beacon enabled communication [11].

Beacon enabled network: Whenever any device wants to communicate with a node or vica-versa, the beacon frames are generated by the network co-coordinator which are responsible for the transmission of data.

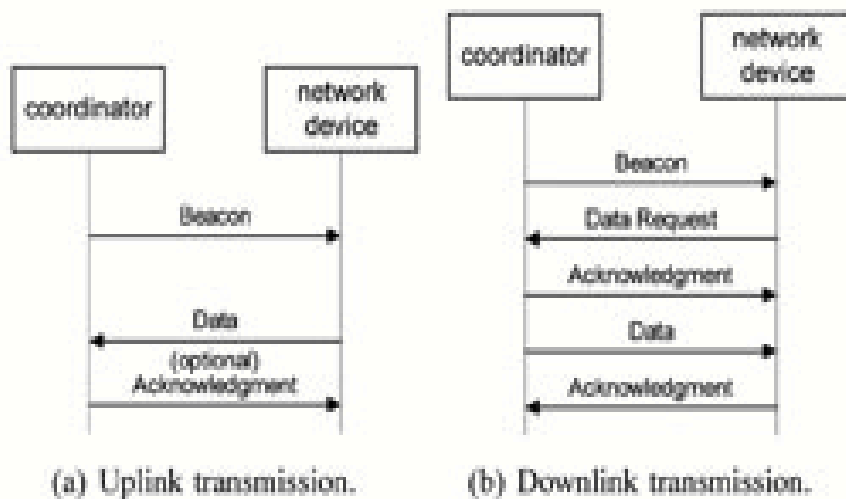

Fig. 3: Data transfer in 802.15.4 PAN in beacon enabled mode.

Non Beacon enabled network: For the non beacon enabled network, beacon frames are randomly transmitted by the co-coordinator from time to time.

3.2 Super frame Structure

When the network is operating in beacon-enabled mode, the channel-time is divided into superframes. PAN decides the format of a super frame structure. No beacons are transmitted when the PAN does not use the super frame format. The communication in a beacon-enabled network takes place during the active portion of the super frame only. The super frame structure set up by the PAN is used to control the channel access. Beacons are transmitted periodically and provides 16 equal-width time slots [13,14] between beacons for contention free channel access in each time slot. However, to improve the quality of service (QoS), the PAN may allocate up to 7 guaranteed time slots (GTS) per beacon and a GTS can occupy more than one slot period. No beacons are transmitted by the pan co-coordinator when the values of Mac Beacon Order and Mac SuperFrameOrder are set to 15 and the GTS shall not be permitted in this state.

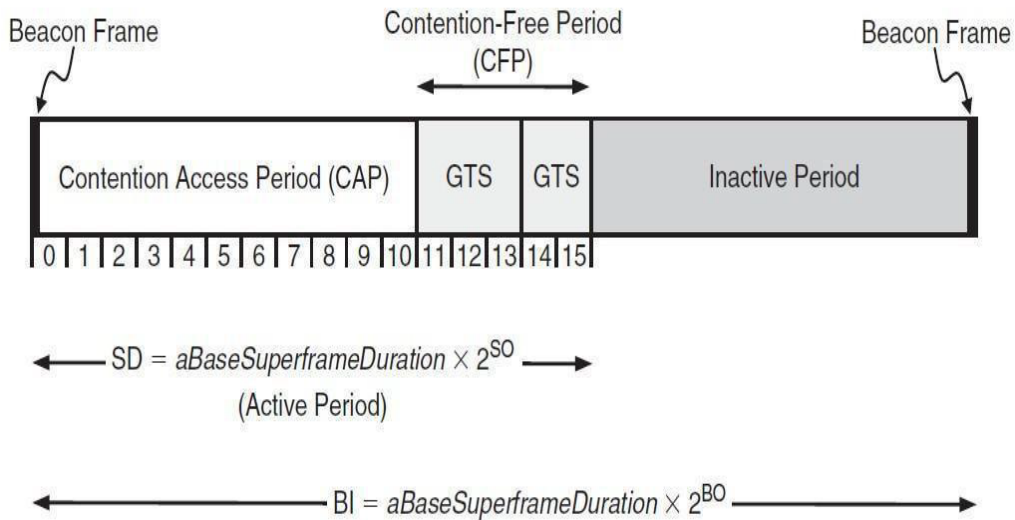

Fig. 4: Super frame Structure.

Every frame structure consists of:

- MAC frame header (MHR), which include frame control, sequence number and address information.
- MAC frame payload (MAC payload) of variable length containing specific frame information.
- MAC frame tail (MFR) that contains FCS.

There are 4 frame types in MAC layer: beacon frame, data frame, request frame and the command frame [16].

REFERENCES

- [1] Chris Evans-Pughe, "Is the zigbee wireless standard, promoted by an alliance of 25 firms, a big threat to Bluetooth?", IEE Review, pp.28-31, March 2003.
- [2] Mikhail Galeev, "Making Friends With Zigbee: Introduction to 802.15.4 Protocol", Class#300, Embedded System Conference, Boston, September 2004.
- [3] Christopher Leidigh, Jim Higgins, "Inside Look at Zigbee Wireless Networks", ESC-252 Embedded Systems Valley, April 2007.
- [4] Ian Poole, "What Exactly Is... Zigbee?", published in IEE Communication Magazine, pp.44-45, August/September 2004.
- [5] Shizhong Chen, Jinmei Yao, Yuhou wu, "Analysis of the Power Consumption for Wireless Sensor Network Node Based on Zigbee", International Workshop on

-
- Information and Electronics Engineering(IWIEE) 29(2012) 1994-1998,doi:10.1016/j.proeng.2012.01.250.
- [6] Abhinav Singh, Pankaj Kumar Patel, "Analysis of Beacon Enabled WPAN using Zigbee",pp. 12-38.
- [7] Zigbee Specification, www.specifications.net/zigbee/zigbee_UK.php.
- [8] Cliff Bowman,"Applying Embedded Wireless Networks", Embedded Systems Conference, San Francisco, Class#349/Boston, Massachusetts, USA, 2004.
- [9] Jelena Mistic,"Zigbee: a long way to go",pp.32-35,april 2007.
- [10] Min Zhou, Hang-long Nie,"Analysis and Design of Zigbee MAC layers protocol", International Conference on Future Information Technology and Management Engineering,2010.
- [11] Abhinav Singh,Pankaj Kumar Patel,P.C.jain,"Performance Analysis of Beacon Enabled IEEE 802.15.4 using GTS in Zigbee",International Journal of Engineering Research and Applications(IJERA),ISSN:22248-9622,vol.2,issue 4,pp.461-465,July/August 2012.
- [12] Abhinav Singh,Pankaj Kumar Patel,P.C.jain,"Analysis of Throughput using GTS and Multichannel in IEEE 802.15.4",International Journal of Advanced Technology & Engineering Research(IJATER),ISSN:2250-3536,vol.2,Issue 2,pp.44-48 March 2012.
- [13] Abhinav Singh, Pankaj Kumar Patel,P.C.jain,"Analysis of Throughput GTS and SDS in IEEE",International Journal of Electronics and Computer Science Engineering,ISSN:2277-1956,vol. 1,number 2,pp.597-602.
- [14] Jelena Mistic,Shairmina Shafi,Vojslav b.Mistic,"Performance Limitations of the MAC layer in 802.15.4 low rate WPAN",Computer Communications 29(2006) 2534-2541,doi:10.1016/j.com.2006.02.005.
- [15] Sinem Coleri Ergen,"Zigbee/IEEE 802.15.4 Summary", September 2004.
- [16] Chia-Mingwu,Ruay-Shiung Chang,Pu-i-lee",An Innovative Scheme for Increasing Connectivity In Zigbee Networks", International Conference on Parallel Processing,doi:10.1109/ICPP.2011.20,2011
- [17] Drew Gislason,"Zigbee Applications-part 1: sending and receiving data", February 2010,www.eetimes.com/general/prinyview/4201087.
- [18] Drew Gislason, "Zigbee Applications-part3:PANS" www.eetimes.com/general/prinyview/4204872, august 2010.
- [19] RFID & GPS Systems & Mobile Based Hardware & Software Trial & Production,www.rfide.com/docs/introductiontowireless_standards.htm.